

RoboSign

Remote controlled Stop/Go temporary traffic control system



Operators Guide

Table of Contents

Introduction	3
Caution	3
Important notes for operators	3
Cleaning	4
RoboSign features	4
Installation	5
Pre installation checks	5
Setting up	5
High wind conditions	6
Operation	7
Operating the RoboSign system	7
One hour standby	7
Fault conditions	7
Single sign operation	8
Troubleshooting	9
Batteries	10
Recharging the base units	10
Recharging the remote control	10
Replacing base unit batteries	11
Removing the electronics enclosure	12
Warranty	13

Introduction

The RoboSign provides a quick and simple solution for controlling traffic through a temporary works site.

Each RoboSign unit consists of a battery powered base box topped with a pole-mounted Stop-Go board. Wireless signals are used to link two RoboSign units with a remote control held by a single operator.

With repeated presses of a single button, a sole operator can progress the RoboSign units through their traffic phases in tune with vehicle conditions and the availability of the shuttle lane.

Caution

- Risk of explosion if batteries are replaced by incorrect types.
- Dispose of used batteries according to the instructions.
- See page 10 for further details about battery disconnection.
- The base units weigh more than 25Kg, do not attempt to move one alone, always work together with a colleague.
- Signs may rotate unexpectedly, always take care when working near a base unit.
- All electronics enclosures of the RoboSign MK 3 system are sealed and contain no user serviceable parts. Any unauthorised modification to these or any other part of the RoboSign MK3 system will invalidate the unit, meaning that the equipment can no longer be used.

Important notes for operators

Please ensure that you closely follow the instructions within this manual when installing and operating the RoboSign MK 3 for temporary traffic control. In particular, the following conditions must all be met when operating the system:

- It must be daylight with good visibility.
 - Two-way traffic flow should not exceed 850 vehicles per hour.
 - The base units must be placed no further than 200 metres apart.
 - All required pre-warning road signs must be in place according to the Road Controlling Authorities guidelines covering the use of manually operated Stop-Go board traffic control.
 - Stop-Go Board must be compliant to NZ Transport Agency Traffic Control Devices Manual. The board must comply with the requirements of Priority hand-held Stop-Go.
 - The operator must have a safe and central vantage point with a clear view of both Stop-Go boards and oncoming traffic.
 - The operator must not be more than 100 metres from either base unit.
- If any of these conditions cannot be met then the RoboSign MK 3 system must not be used. If any of these conditions change during operation, you must cease using the system.

This system must be installed and operated only by fully trained and experienced personnel. If you are in any doubt about correct procedures or if you are concerned about safety please cease using the system. Equipment must only be repaired by CSP Pacific or an authorised repair agents.

Cleaning

Wipe the exterior of the base units with a damp cloth. Do not use pressure washers or steam cleaners.

RoboSign features

The RoboSign units and remote control are compact and straightforward to set up and operate.

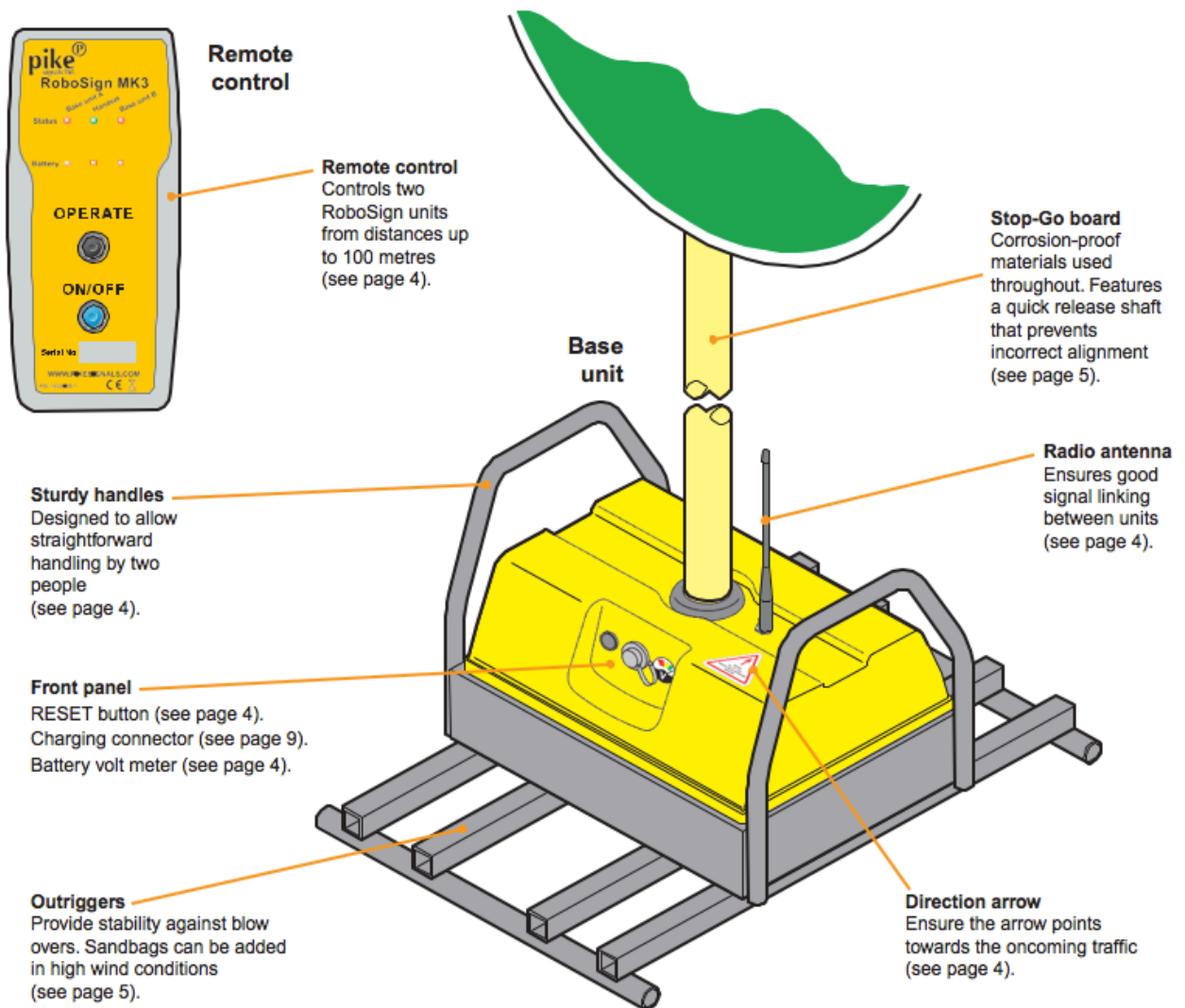

Installation

Pre-installation checks

It is important to inspect all parts of the system before attempting to use them for traffic control. Please carry out the following checks:

- Confirm that both base units and the remote control are all MK3 (earlier models cannot be mixed):

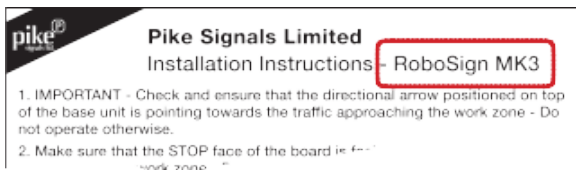

Base units: Clearly marked with RoboSign MK3



Remote control: Clearly marked with RoboSign MK3

- Check that both base units and the controller are properly charged:



Base units: The volt metre needle should be in the green area. If not, the unit needs to be charged (see page 8)



Remote control: The top centre green indicator should be on, the lower centre indicator should be off (see page 7)

Setting up

- 1 Ensure that no other RoboSign systems are within 1000 metres of your installation.
- 2 Ensure the supplied antennas are fitted to the two base units and the remote control. If the Stop-Go boards are attached to the base units, remove them.
- 3 At each end of the works zone, place a base unit where it will be clearly seen by drivers but will not cause an obstruction to vehicles or pedestrians. The base units should not be more than 200 metres apart.

Note: As base units weigh more than 25Kg, do not attempt to move one alone.

Ensure that the arrow sticker on the top panel of each base unit points towards the approaching traffic:



- 4 On the remote control, press the **ON/ OFF** button to switch it on. The centre green Status indicator should illuminate, followed by the two red Status indicators either side a few seconds later. If this does not occur, please see page 9.
- 5 On one of the base units, press the front panel **RESET** button that is located next to the charging connector. This will switch the unit on and prompt it to search for the controller. When the **base unit** and remote control make contact, the red **Base unit A** status indicator on the remote control will go out.
- 6 Repeat steps 3 and 5 on the other base unit. When that base unit and the remote control make contact, the red **Base unit B** status indicator on the remote control will go out.



- 7 Operate the system through one complete cycle (see the Operation section on page 7) and check that the shafts of the base units rotate in the correct sequence.

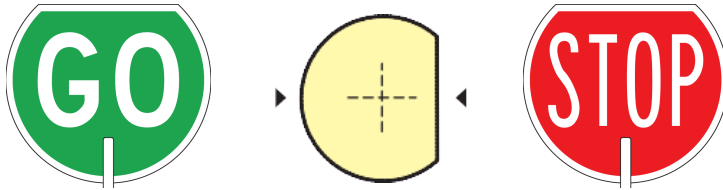

The flat (keyway) side of each shaft is the side on which the STOP sign will be located

Assistance may be required to perform this operation.

- 8 After performing the checks described in step 5, the flat side of each base unit shaft should be facing towards the approaching traffic. When traffic conditions allow, attach a Stop-Go board to each base unit shaft. The pole of each Stop-Go board can only be fitted one way onto each shaft. Once fitted, the Stop side of each board should be facing towards the approaching traffic:

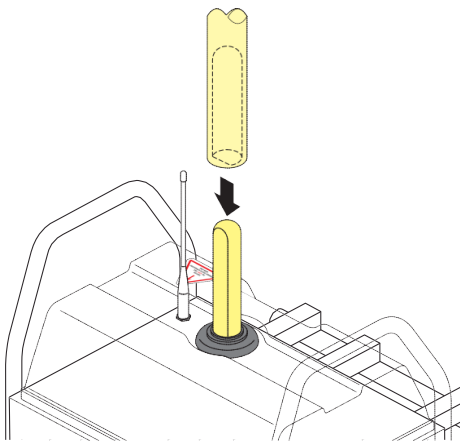

Once the poles are attached, your installation should be ready. See the Operation section on page 7.

Align the keyed hole of the pole with the base unit shaft. Then slide the pole all the way down onto the shaft.

High wind conditions

In high winds each base unit can be stabilised by placing a sandbag or similar on the frame outriggers.

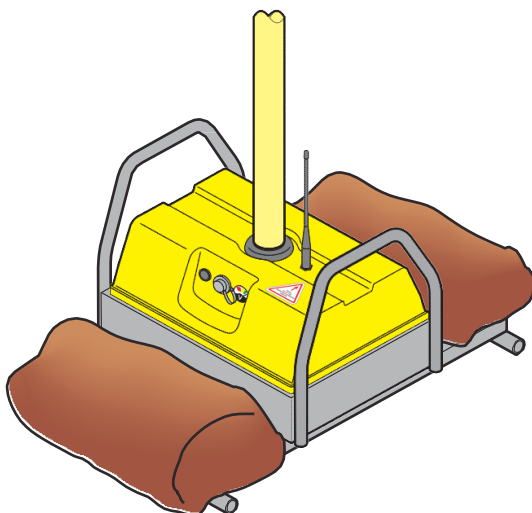

Sandbags may be added for additional stability in high wind conditions.

Important: Do not install or operate RoboSign units in bad visibility or extreme wind conditions.

Operation

Operating the RoboSign system

- 1 Ensure that you are in a safe, central vantage point with a clear view of both Stop-Go boards and the oncoming traffic.
- 2 Check that both Stop-Go boards are displaying **STOP** to their approaching traffic streams. If either unit is not doing this, do not attempt to operate the system.
- 3 Observe that the approaching traffic has stopped at both ends of the work zone and that the shuttle lane is clear.
- 4 Hold the remote control handset upright and press the **OPERATE** button. One of the base units will spin its board through a half-turn to show a **GO** signal.
- 5 After an appropriate period of time, and in response to traffic conditions, press the **OPERATE** button to change to the next state (see *Operation sequence* right for details).
Note: After each button press, the remote control will ignore any further presses for four seconds.
- 6 Repeat step 5 to advance to the next step of the sequence.

One hour standby

If the system is not used for a period of one hour, the base units and the remote control will automatically switch themselves off to conserve battery power. Any base unit sign that is at **GO** will turn to show **STOP**.

To re-activate the remote control

- Press the **ON/OFF** button on the remote control.

To re-activate each base unit

- Press the **RESET** button on the base unit front panel.

Fault conditions

During operation if a fault is sensed (such as power loss, radio interference, etc.), the fail-safe system will automatically ensure both units are returned to their **STOP** positions and an indication may be given on the remote control.

See the Troubleshooting section on page 9 for details. If the system is unable to be operated, the Stop-Go boards can be removed from the base units and used manually.

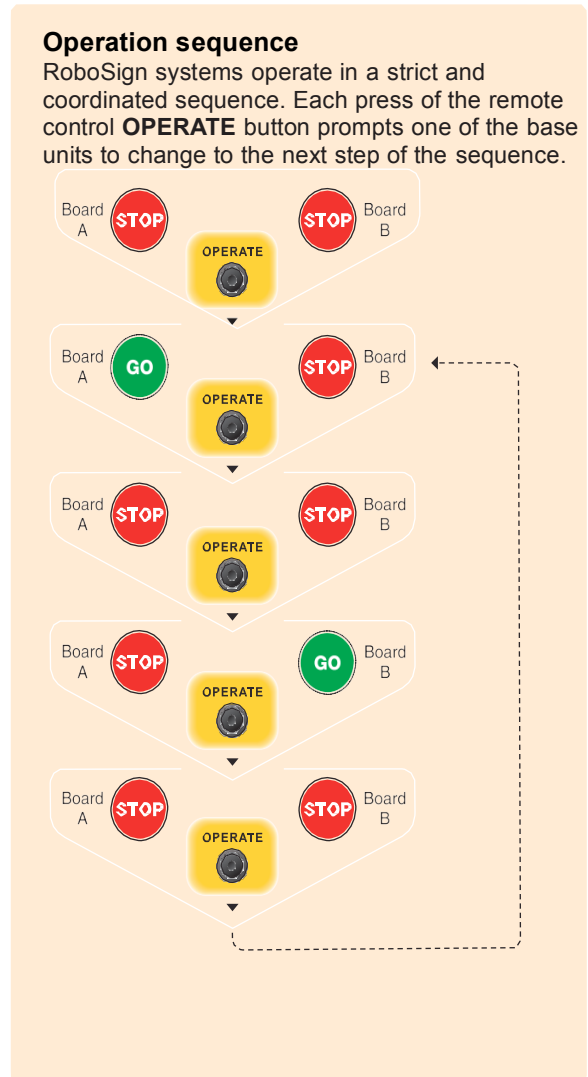

Single sign operation

In addition to the usual dual sign operation (as explained on the opposite page), you can use a single RoboSign base unit to control very short shuttle lanes where both traffic streams can clearly see the sign.

- 1 Ensure that no other RoboSign systems are within 1000 metres of your installation.
- 2 Ensure the supplied antennas are fitted to the base unit and the remote control. If the Stop-Go board is attached to the base unit, remove it.
- 3 Place the base unit where it will be clearly seen by drivers but will not cause an obstruction to vehicles or pedestrians.
Note: The base unit weighs more than 25Kg, do not attempt to move it alone.
- 4 On the base unit, press the front panel **RESET** button that is located next to the charging connector. This will switch the unit on and prompt it to search for the controller.
Note: If the base unit is in the Go position before you switch it on, this will cause an error when it is powered on (forcing it to automatically power down again). You will need to manually turn it to the Stop position before powering it on.*
When the base unit and remote control make contact, the red **Base unit A** status indicator on the remote control will go out.
- 5 On the remote control, press and hold the **OPERATE** button for approximately 10 seconds, until the **Base unit B** red status indicator goes out.
The system is now in single sign mode. The sign will rotate with every press of the **OPERATE** button.
Note: After each button press, the remote control will ignore any further presses for four seconds.
- 6 Operate the system (without the Stop-Go board) through one complete cycle.
- 7 When traffic conditions allow, attach the Stop-Go board to the base unit shaft (the pole can only be fitted one way onto the shaft). The flat (keyway) side of each shaft is the side on which the STOP sign will be located.

Notes:

- Base units always power on into standard mode, so even if it was last used in single sign mode, you will still need to go through the whole startup process shown left (steps 4 to 7).
- When a base unit has been used in single sign mode and is then switched off in its *Go position**, either automatically or by the operator, then this will cause an error when it is powered on (forcing it to automatically power down again).
- If the base unit is currently off and in the *Go position**, you will need to manually turn it to the Stop position before powering it on.
- When operating in single sign mode (rather than standard dual sign mode), the base unit will react differently if a problem is discovered. Upon discovery of a problem, the base unit will simply remain in its current position and power down.

* *The Go position is when the Go sign is pointing in the direction of the arrow sticker on the top panel of the base unit. If the sign is not fitted you will see that the flat keyway of the shaft is facing away from the arrow sticker direction.*

Troubleshooting

Note: After any serious fault, follow the Setting up instructions given on page 5. If the system fails to operate, please follow these basic steps:

- 1 Ensure that both base units have been switched on using their **RESET** buttons on the front panels.
- 2 Ensure that the battery power metre on each base unit shows green or yellow. If not, the batteries of the unit will require charging before the system will operate.
- 3 If both the base units are not working, the problem may be with the remote control. Change the remote control batteries.
- 4 If the units still do not function the problem may be within the remote control handset. This is a sealed unit and contains no user serviceable parts so please contact CSP Pacific.
- 5 Check that the STOP board is facing in the direction of the direction arrow label. If not, manually rotate the sign to the STOP position, then press the **RESET** button.

Caution: If the sign rotates, it will do so with force.

If the board does not rotate it may be a problem with the **RESET** switch. This can be checked visually by removing the four screws of the base unit cover and carefully removing it. Inspect the back of the **RESET** switch and ensure that the two wires are securely connected to it.

- For information on spares or repair, contact CSP Pacific.
- If there is no problem with the **RESET** switch, the problem must be within the sealed electronics housing. This contains no user serviceable parts, contact CSP Pacific.

6 Check that all antennas are fitted and not damaged.





7 Check the remote control indicators **Ü**

To reset the system

- 1 Switch the remote control off and then on using the **ON/OFF** button.
- 2 Wait for remote control to display permanent green and red indicators.
- 3 Reset one of the base units: Press its front panel **RESET** button.

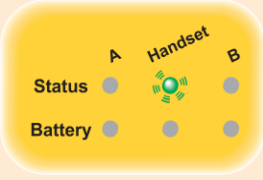
Note: If the original problem was a forced sign, when you press the **RESET** button the sign may rotate; if so, once the sign stops, repress the **RESET** button.

4 Repeat step 3 for the other base unit.

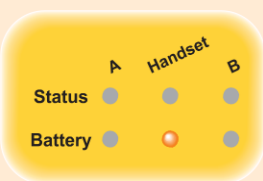
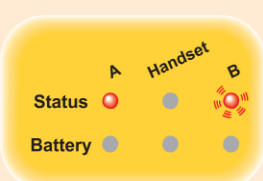
	Normal operation
	Communication loss with base unit A
	Communication loss with base unit B
	Low battery in remote control (similar indication for base units if the A or B amber indicators flash)
	Fully discharged battery in remote control (similar indications for base units if the A or B amber indicators are permanently lit)
	Serious fault detected on base unit A (similar indication for base unit B) Please follow the Troubleshooting steps shown left.

Batteries

Recharging the base units

The RoboSign MK 3 system is supplied with a three stage charger to charge the internal batteries of each base unit.

IMPORTANT:

- **Never operate a RoboSign unit while the batteries are being charged.**
- **Do not use a charger other than that supplied by CSP Pacific for use with the RoboSign MK 3 system base units.**
- **The base units weigh more than 25Kg, do not attempt to move one alone.**
- **The sign may rotate unexpectedly, always take care when working near a base unit.**

To charge a base unit

- 1 Insert the plug from the supplied charger into the corresponding socket on the front panel of the base unit.
- 2 Insert the mains plug into a suitable electricity socket outlet and switch on. The charge cycle for a base unit is approximately 12 – 14 hours. The charger will automatically cease charging when the cycle is complete.

Note: The charger unit requires a 230VAC, 50Hz mains supply. It has a power requirement of 125W.

The status of the recharge cycle is indicated on the front of the charger:

- **Red** – power is being supplied to the battery charger.
- **Amber** – the battery attached to the charger is being charged.
- **Green** – the recharge cycle is complete.

Recharging the remote control

The remote control uses four standard AA type batteries and these can be replaced with rechargeable batteries. Rechargeable AA batteries will need to be removed and charged in a third-party charger unit.

To remove and refit remote control batteries

- 1 Using an SW3 (3mm) hex key, remove the two bolts from the rear panel of the remote control.
- 2 Remove and if rechargeable batteries are used, charge in a third party charger unit.
- 3 Replace the batteries into the remote control, taking care to ensure correct polarity (as marked within the casing).
- 4 Replace the rear remote control panel and the two bolts.

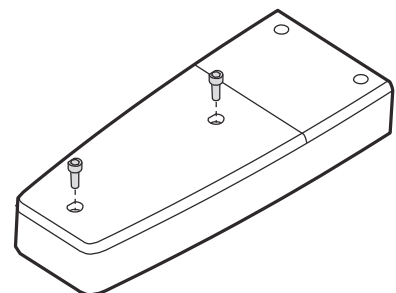

Replacing base unit batteries

Each base unit uses two sealed lead acid rechargeable rated at 12V 20Ah non-maintenance or equivalent. These provide a minimum, 100 hours of operation when fully charged.

IMPORTANT: You are recommended to replace the base unit batteries as a pair. Do not use any other battery or charger than those supplied by CSP Pacific.

To replace the base unit batteries

- 1 Remove the four fixing screws holding the yellow top cover to the main frame.
- 2 Carefully lift the yellow top cover (take care as the front panel is wired to the main chassis) and place next to the unit.
- 3 Locate the batteries and their fixing straps
- 4 Remove the negative (black) and then live (red) connections to the batteries.
- 5 Remove the bolts from both ends of each battery strap.
- 6 Remove the old batteries and replace them with ones of the same specification.
- 7 Replace the battery straps and bolts.
- 8 Replace the live (red) and then negative (black) connections to the batteries.
- 9 Replace top cover onto base frame.
- 10 Replace four fixing screws to hold top cover onto main frame.
- 11 Perform a full test of the base unit in a safe environment before placing it back into service.

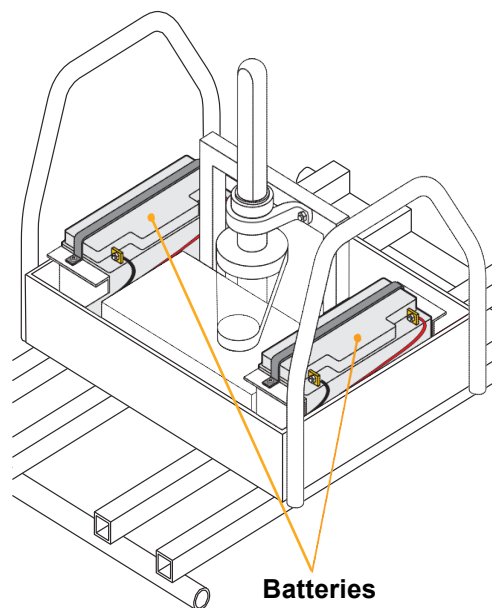

Removing the electronics enclosure

In certain circumstances it may be necessary to remove and replace the electronics enclosure.

Note: *The electronics enclosure is a sealed unit and does not contain any user serviceable parts. Do not attempt to open it under any circumstances as this will invalidate the unit and the warranty.*

To remove the electronics enclosure

- 1 Remove the four fixing screws holding the yellow top cover to the main frame.
- 2 Carefully lift the yellow top cover (take care as the front panel is wired to the main chassis) and place next to the unit.
- 3 Locate the electronics enclosure:

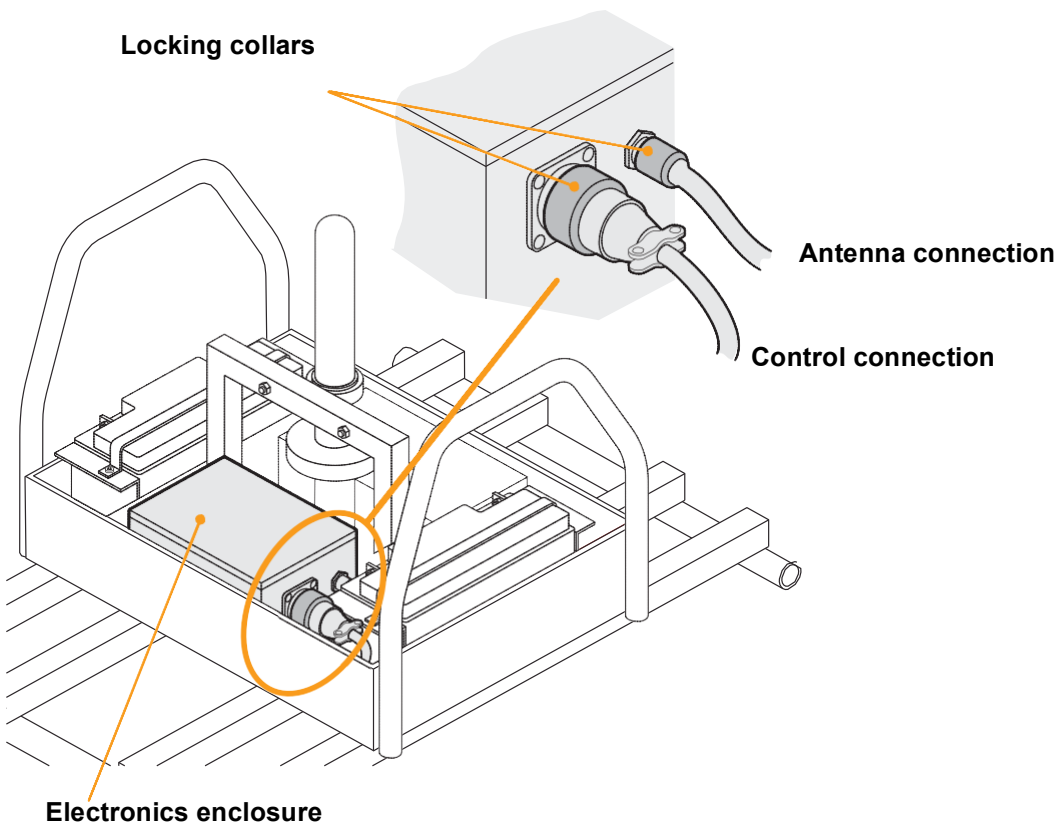

- 4 Disconnect the antenna and control connector connections (twist their locking collars anti- clockwise to release) from the electronics enclosure.
- 5 Remove the two M4 bolts that secure the electronics enclosure to base main frame.
- 6 Extract the electronics enclosure from the base unit.

Warranty

RoboSign base units and the remote control are guaranteed against failure subject to fair wear and tear, correct operation and return to CSP Pacific at customers cost. We undertake to repair or replace this equipment free of charge providing:

- It has been maintained in good condition and operated with due care, and
- Any failures are directly traceable to faulty material or workmanship.

However, any claims for labour or other expenditure in connection therewith. Items or components subject to another manufacturer's guarantee are not covered and are subject to the terms of that guarantee only.

Any warranty given is void if seals on equipment are subsequently found to have been broken without prior permission by CSP Pacific.

Any item of equipment repaired by CSP Pacific is guaranteed from failure for three months from the date of repair, provided that the item has been subjected to fair usage and regular maintenance.