

# muck-truck



*It doesn't cost the earth to move it!*

## Muck-Truck Mk V Dumper MAX Mk III Dumper

### Owner, Operation, & Parts Manual

---

#### Models

Muck-Truck Mk V Dumper

MAX Mk III Dumper

Starting with Serial Number 10001

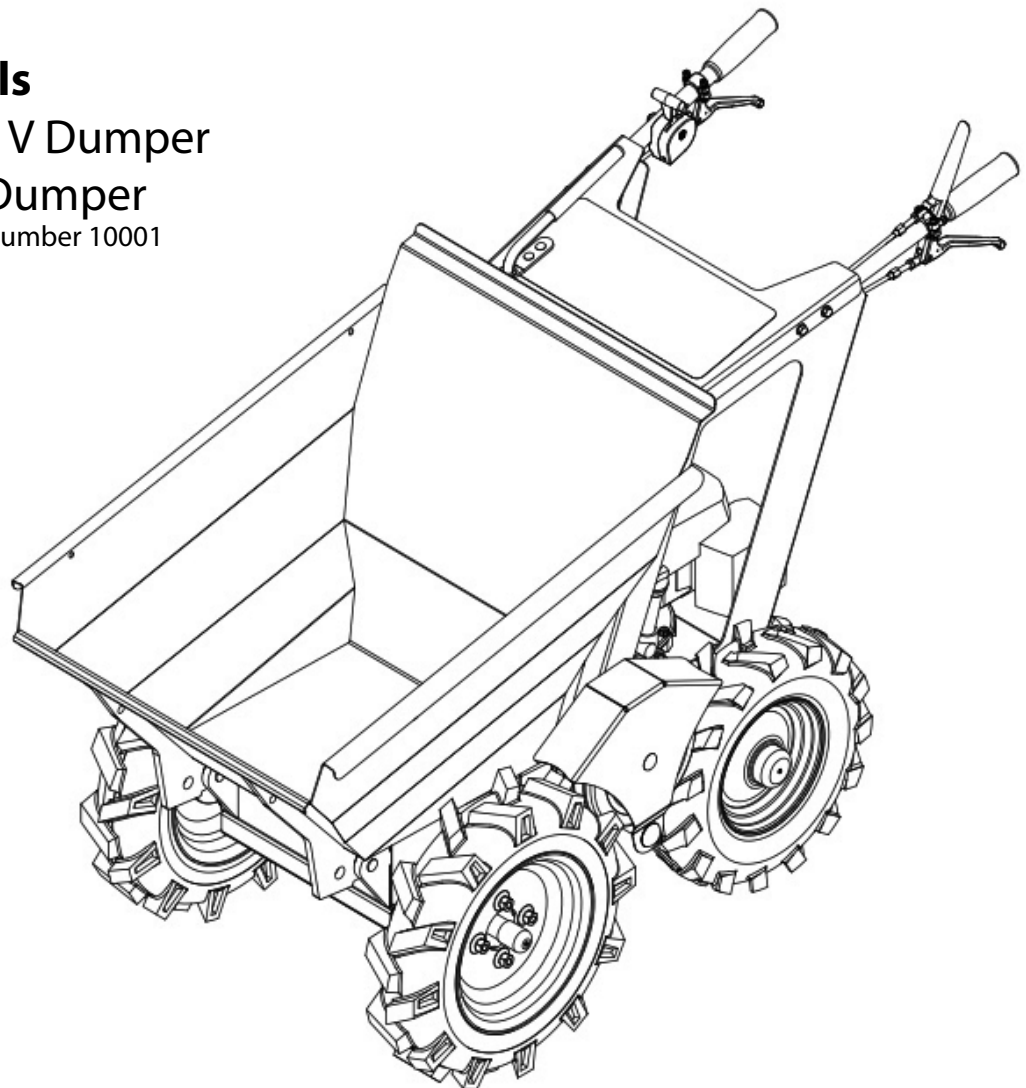

# TABLE OF CONTENTS

ASSEMBLY.....	3	SERVICE AND ADJUSTMENTS.....	9
SAFETY.....	4	PARTS LIST.....	12
CONTROLS AND FEATURES.....	5	WARRANTY.....	18
OPERATION.....	6		
MAINTENANCE.....	8		

# INTRODUCTION

## THE MANUAL

Before using the unit, carefully and completely read your manual. The contents will give you an understanding of safety instructions and controls during normal operation and maintenance.

All reference to left, right, front, or rear is given from the operator's position, facing the direction of forward travel.

## ENGINE MANUAL

A separate manual specific to the engine covers the engine on this unit. This manual is included in the literature package that shipped with the unit. Refer to this manual for engine service recommendations. If the engine manual is not available, contact the engine manufacturer for a replacement manual.

## PURCHASE INFORMATION

Please record the following information about your unit and have it available before contacting us.

Serial Number:

Dealer/Distributor's Name:

Date of Purchase:

Year of Manufacture:

# DECLARATION OF CONFORMITY

The undersigned of Muck Truck UK Ltd, declare that the Pedestrian Dumper Trucks:

**Category:** Petrol, 4-Stroke Pedestrian Dumper

**Model:** Muck-Truck Mk V Dumper / MAX Mk III Dumper.

Conform to the essential Health and Safety requirements of the EEC Directive.

98/37/EC (Edition L 207)

Previously 89/392/EEC – 93/94/EEC Amendment

Basic Noise Emission Standard – EN ISO 3744 – dB 98 Lwa

## H.A.V.s

Machinery Directive 89/392/EEC

The supply of (Safety) regulations 1992 (as amended: 1994), for conformity in an EU market

**Left Hand** Idle: 2.79 m/s<sup>2</sup>      **Right Hand** Idle: 3.10 m/s<sup>2</sup>  
Racing : 4.95 m/s<sup>2</sup>                      Racing : 5.86 m/s<sup>2</sup>

Specified testing unit to: ISO 8041, ISO 5349 and BS 6842

The notified body is AV Technology Ltd.

Avtech House, Birdhall Lane, Cheadle Heath, Stockport, SK3 0XX, England

Name and signature of Managing Director of Muck Truck UK Ltd.



Terry Rowlands

# ASSEMBLY

## Install Handles

Handles are shipped in downward position (see Figure 1) with all levers and cables correctly positioned.

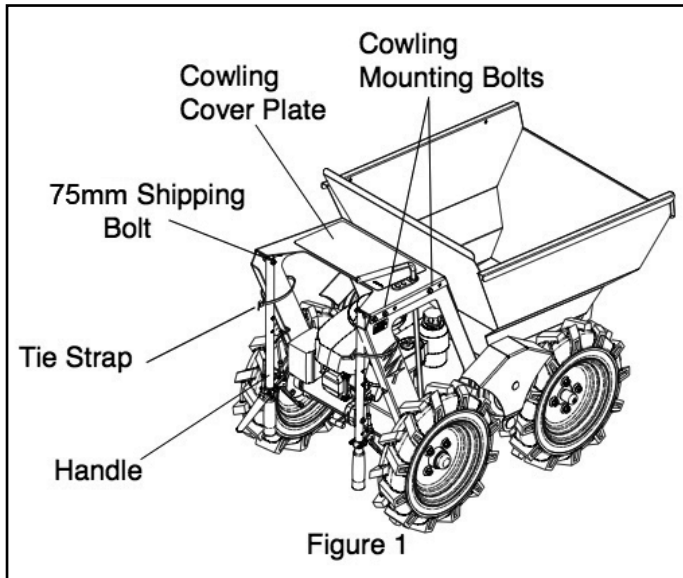

1. Cut tie-straps retaining handles.
2. Remove M8 x 75 shipping hex bolt securing handle to unit. Retain nut and washers; discard 75mm hex bolt.
3. Align handle with the holes in the cowling cover and attach with two M8 x 50 bolts, washers and M8 Nyloc nuts removed earlier.

4. Insert M8 x 50 hex bolt from Manual Package into remaining hole and secure with washers and nut removed from shipping bolt.
5. Tighten hardware securely.
6. Repeat steps 2 – 5 for remaining side.

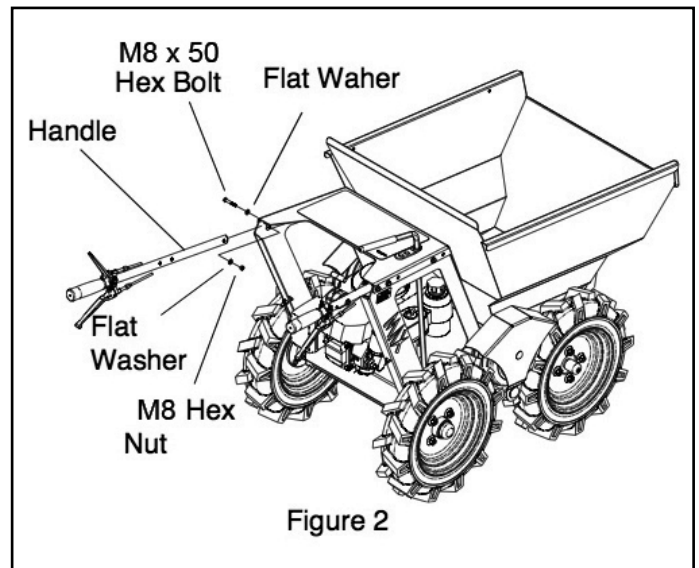

# SAFETY



OL1253

## SAFETY ALERT SYMBOL

These are safety alert symbols. They mean:

- **ATTENTION!**
- **YOUR SAFETY IS INVOLVED!**



OL3900

When you see this symbol:

- **BECOME ALERT!**
- **OBEY THE MESSAGE!**

## SIGNAL WORDS

The safety alert symbols above and signal words below are used in this manual.

Read and understand all safety messages.



OL1253

**DANGER: IMMINENTLY HAZARDOUS SITUATION!** If not avoided, WILL RESULT in death or serious injury.



OL1253

**WARNING: POTENTIALLY HAZARDOUS SITUATION!** If not avoided, COULD RESULT in death or serious injury.



OL1253

**CAUTION: POTENTIALLY HAZARDOUS SITUATION!** If not avoided, MAY RESULT in minor or moderate injury. It may also be used to alert against unsafe practices.

## SAFETY RULES

Read, understand, and follow all safety practices in Owner/Operator Manual before use. Failure to follow instructions could result in personal injury and/or damage to unit.

Complete a walk around inspection of unit and work area to understand:

- Work area
  - Your unit
  - All operational decals.
- Inspect unit before each use for: missing or damaged decals and shields. Replace or repair as needed.

Keep children out of work area and under watchful care of a responsible adult.

Check for weak spots on docks, ramps or floors. Avoid uneven work areas and rough terrain. Stay alert for hidden hazards or traffic.

DO NOT operate near drop-offs, ditches, or embankments. Unit can suddenly turn over if wheels move over the edge of a cliff or ditch, or if an edge caves in.

Read the entire Owner/Operator manual. If the operator or the mechanic cannot read the manual, it is the owner's responsibility to explain it to them. Only the user can prevent, and is responsible for accidents or injuries occurring to themselves, other people or property.

Only trained adults may operate or service unit. Training includes actual operation.

NEVER operate unit after or during the use of medication, drugs or alcohol. Safe operation requires your complete and unimpaired attention at all times

Wear adequate safety gear, protective gloves and footwear. NEVER place your hands or any part of your body or clothing inside or near any moving part while unit is running.

DO NOT touch parts that are hot. Allow parts to cool.

ALWAYS keep hands and feet away from all pinch points.

Read, understand, and follow all instructions in the manual and on the machine before starting. Understand:

- How to operate all controls.
- The functions of all controls.
- How to STOP in an Emergency.
- Braking and turning characteristics.

Keep safety devices or guards in place and functioning properly. NEVER modify or remove safety devices.

Never carry passengers. Use only attachments and accessories designed for your unit.

Know the weight of loads. Do not exceed maximum capacity of unit.

Use caution when backing up. ALWAYS back up slowly. Always look down and behind before and while backing. Check all hardware at regular intervals. Keep all nuts, bolts, and wheel nuts properly tightened.

Disengage unit drive by releasing clutch lever before changing gears.

Never leave a running unit unattended. ALWAYS shut off engine before leaving unit. This product is equipped with an internal combustion type engine. DO NOT use unit on or near any unimproved, forest-covered or brush covered land, dirt, grease, oil or other flammable material, unless

exhaust system is equipped with a spark arrester meeting applicable local, state or federal laws.

A spark arrester, if used, must be maintained in effective working order.

Fumes from engine exhaust can cause injury or death. Ensure proper ventilation. Do not run engine in a confined area.

## CONTROLS AND FEATURES

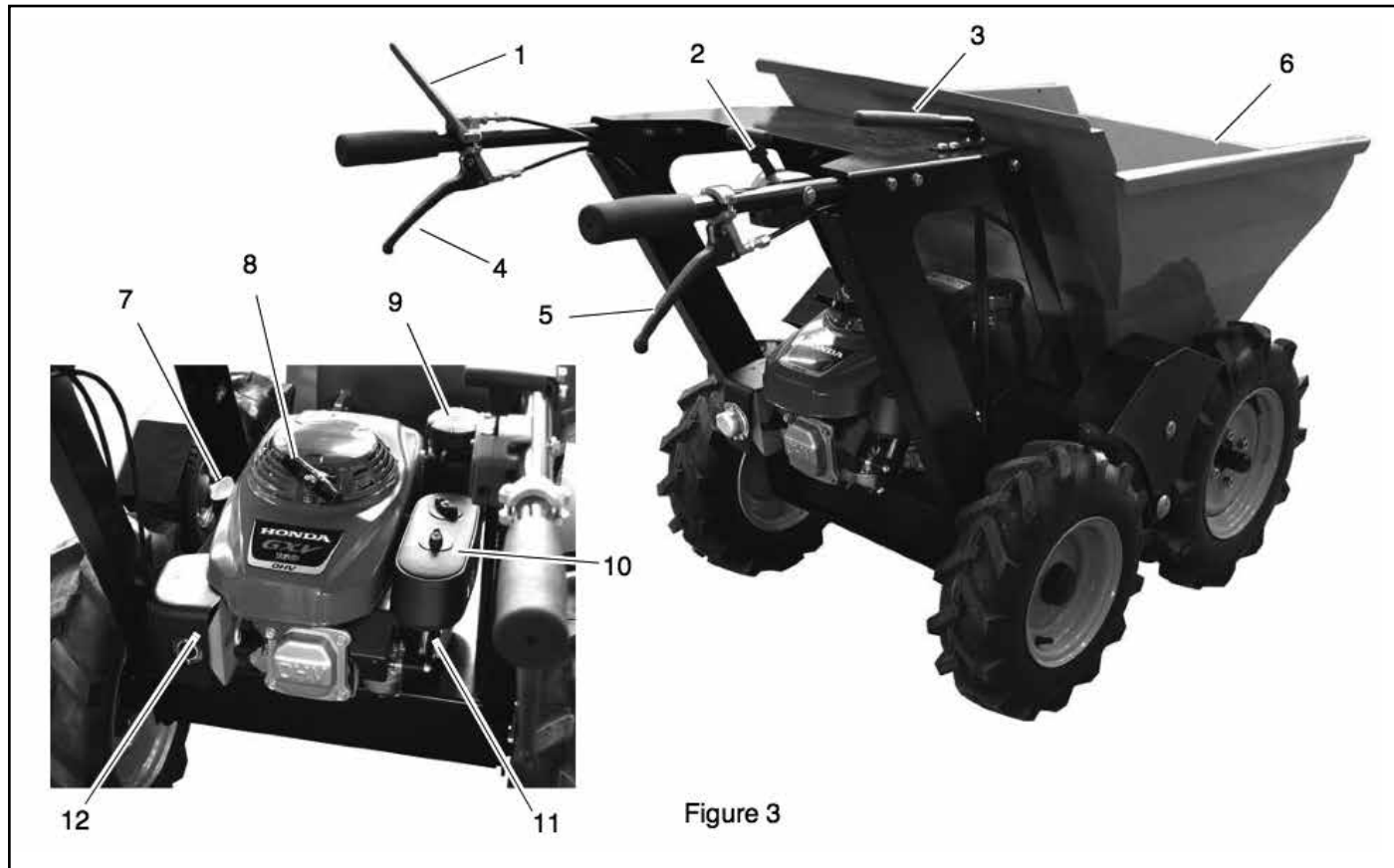

Figure 3

- |                         |                            |
|-------------------------|----------------------------|
| 1. Parking Brake Lever  | 7. Oil Level Dipstick/Fill |
| 2. Throttle Lever       | 8. Recoil Starter Handle   |
| 3. Gear Selection Lever | 9. Fuel Tank/Cap           |
| 4. Clutch Lever         | 10. Air Cleaner            |
| 5. Skip Release Lever   | 11. Fuel Shut-off Valve    |
| 6. Skip                 | 12. Silencer               |

# OPERATION

## CONTROLS AND FEATURES

See *CONTROLS AND FEATURES* on page 5.

### Throttle Lever

(Figure 4)

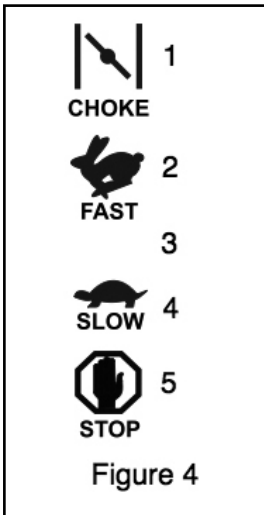

The throttle lever controls the choke position and the engine speed. To choke the engine for startup adjust to:

1. CHOKE (startup)
- To increase or decrease the engine speed, adjust to:
  2. FAST
  3. Part-Throttle
  4. SLOW To stop the engine, adjust to
  5. STOP (engine is off)

### Parking Brake Lever

(Figure 5)

Engage the parking brake by releasing the lever when not traveling with the unit or while emptying the skip. The parking brake lever must be disengaged (pressed down against handlebar) any time that the unit is in motion.



**CAUTION:** Avoid damage. Unit has sufficient power to overpower the parking brake. Not releasing parking brake while traveling will lead to overheating and premature wear of the parking brake.

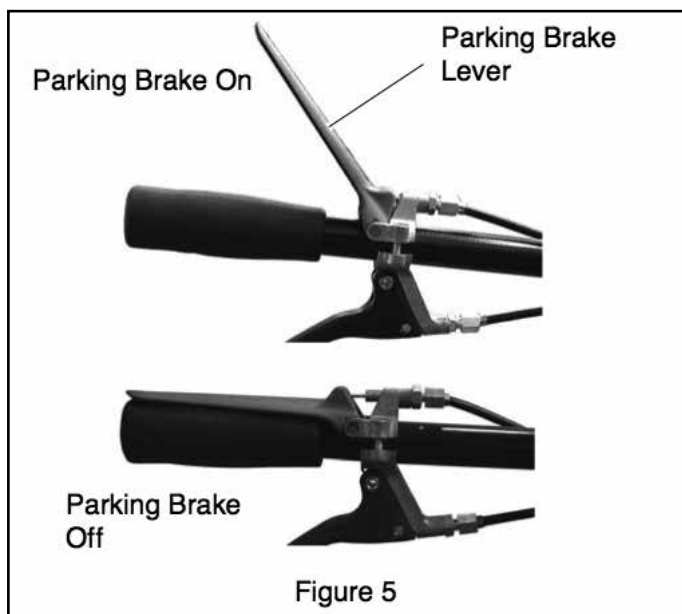

### Clutch Lever

(Figure 6)

With a forward or reverse gear selected, gently engage (squeeze) the clutch lever to move the unit forward or backward. Release the clutch lever to stop motion.

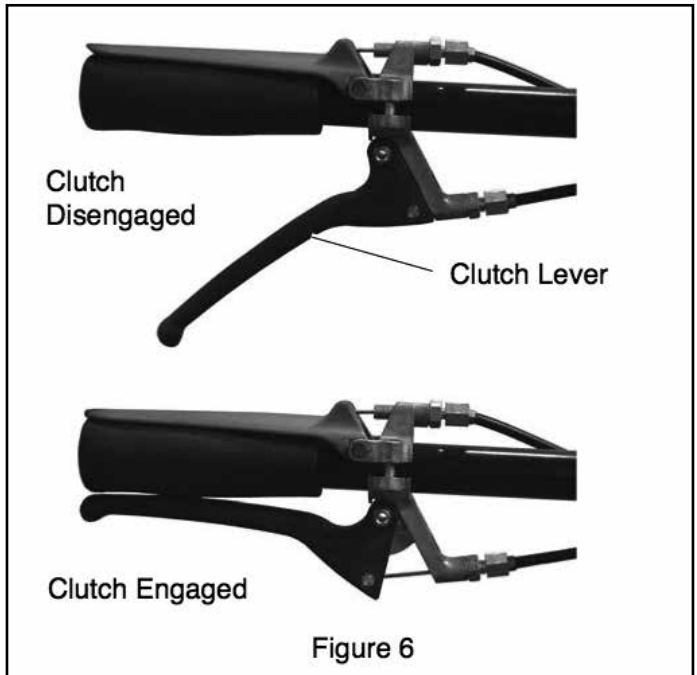

### Gear Selection Lever

The gear selection lever controls forward and reverse motion of the unit and adjusts the forward travel speed. Select the desired gear based on travel conditions.

### Skip Release Lever

(Figure 8)

Squeeze the skip release lever to release the skip lock. Release the skip release lever to engage the skip lock.

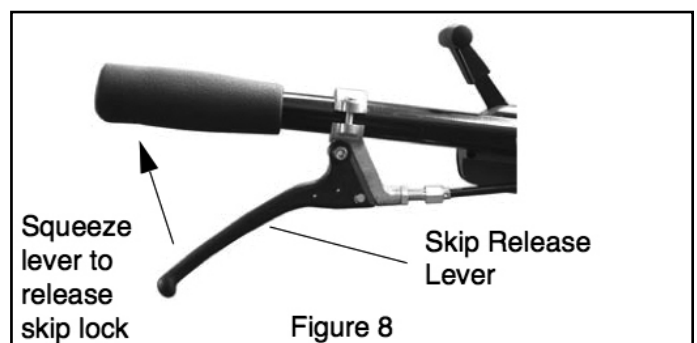

## PRE-START



**WARNING:** AVOID INJURY. Read and understand the entire Safety section before proceeding.

Park unit on level surface. Check and add fuel if required. Check that the engine crankcase oil is full using dipstick. Refer to Engine Manual for detailed instructions.

### Fuel Shut-Off Valve

(Figure 5)

**NOTE:** Close the fuel shut-off valve before transporting the unit.

The fuel shut-off valve has two positions:

- Closed Position – Use this position to service, transport, or store the unit.
- Open Position – Use this position to operate the unit.

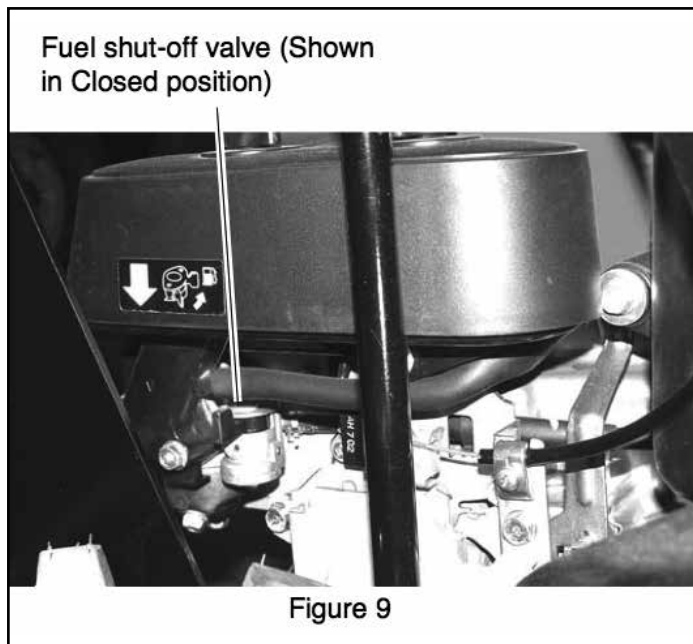

### Adding Fuel

1. ALWAYS place unit in open or well-ventilated area.
2. Stop engine and allow to cool.
3. Remove accessory or tilt forward to gain access to fuel tank.
4. Clean fuel cap and surrounding area to prevent dirt from entering fuel tank.
5. Remove cap.

**NOTE:** DO NOT add oil to fuel. DO NOT use gasohol or gasoline containing alcohol. See Engine Manual for correct type and grade of fuel.

6. Fill fuel tank to within 1/2 in. (1.2 cm) of bottom of filler neck with unleaded fuel.
7. Replace fuel cap and tighten.
8. ALWAYS clean up any spilled fuel.

### STARTING UNIT

**NOTE:** A warm engine requires less choking than a cold engine.

1. Move the throttle lever into the choke position by moving it fully forward.
2. Grasp recoil starter handle and pull rope out slowly until it engages.
3. Pull rope with a rapid continuous full arm stroke. Let rope rewind slowly.

**NOTE:** DO NOT let starter handle snap back against engine.

4. Repeat steps 2 and 3 until engine starts.
5. Move throttle lever to the rear to disengage the choke and set engine speed to idle.
6. Allow engine to warm.
7. Set throttle to desired position based on travel conditions and gear selected.

### OPERATION

#### To Move Forward

1. Select desired speed with gear selection lever.
2. Press parking brake lever down to handlebar.
3. Gently engage clutch lever.

#### To Move In Reverse

1. Stop forward travel of unit.
2. Move gear selection lever to reverse position.
3. Press parking brake lever down to handlebar.
4. Check behind for obstacles and ensure that travel path is clear.
5. Gently engage clutch lever.

#### To Stop Unit

1. Release clutch lever.
2. Release parking brake lever.
3. Reduce engine speed with the throttle control lever.

### To Empty Skip

1. Stop unit and release parking brake lever.
2. Release the skip lock by squeezing the skip release lever.
3. Jerk both handlebar handles upwards. The skip will pivot forward and dump the load.

### To Reset Skip

1. Pull back on the skip.
2. Engage the skip lock by releasing the skip lock lever.
3. Ensure that skip lock has engaged before moving unit.

## MAINTENANCE

### MAINTENANCE CHECK LIST

Perform routine checks as outlined below. Correct any problems before using unit.

Component	Daily	Weekly
Skip Lock Spring	X	
Drive Belt Tension		X
Parking Brake Adjustment	X	
Control Cable Condition & Adjustment	X	
Air Cleaner		X
Engine Oil Level *	X	
Tire Pressures	X	
Attaching Hardware		X

\*SAE 10W-30 oil is recommended for general use. Refer to engine manual for engine maintenance procedures.

### Tyre Pressure

- Check tyre air pressures regularly. Recommended inflation pressure is 2.8 bar (30 psi) for all tyres.

### LUBRICATION

Apply spray lubricant to skip release as necessary. DO NOT use oil or grease.



**CAUTION:** Avoid injury! Explosive separation of tyre and rim parts is possible when they are serviced incorrectly:

- Do not attempt to mount a tyre without the proper equipment and experience to perform the job.
- Do not inflate the tyres above the recommended pressure.
- Do not weld or heat a wheel and tyre assembly. Heat can cause an increase in air pressure resulting in an explosion. Welding can structurally weaken or deform the wheel.
- Do not stand in front of, or over the tyre assembly when inflating.



# SERVICE AND ADJUSTMENTS

## LEVER ADJUSTMENTS

(Figure 10)

Primary clutch and skip release cable adjustments are made at the levers. To adjust:

1. Loosen lock nut (item 1).
2. Adjust cable by rotating adjustment nut (item 2). Moving adjustment nut away from the lever will result in earlier engagement.
3. Tighten lock nut.

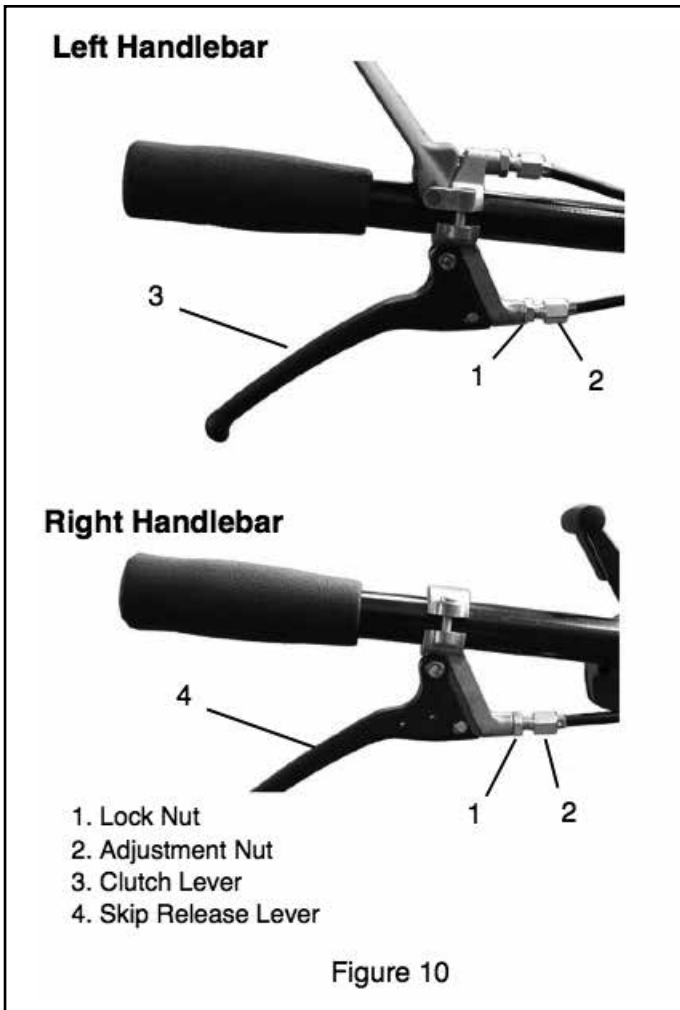

## ADDITIONAL ADJUSTMENTS

(Figure 11)

If clutch, or skip release cable adjustments at the levers are insufficient, additional adjustments can be made to the cables under the unit:

1. Place unit in service position (See Service Position in this section).
2. Loosen lock nuts on the cable.
3. Adjust cable to desire position.
4. Tighten lock nuts.

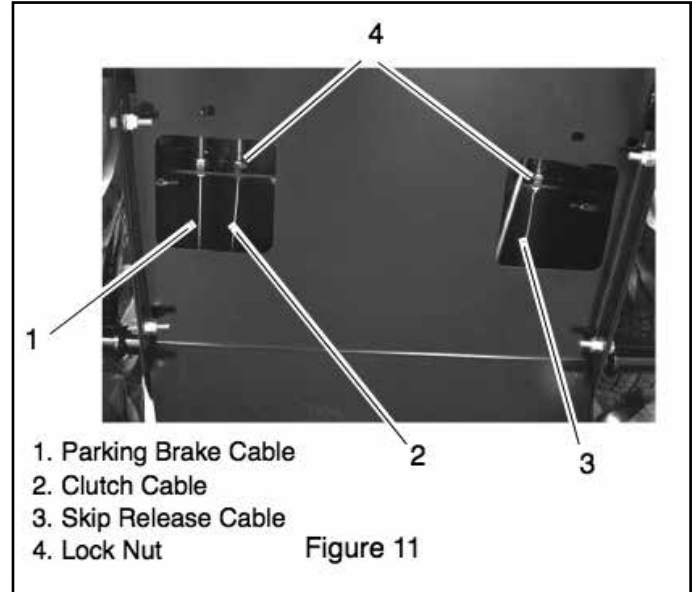

## Parking Brake Disc

(Figure 12)

If the cable adjustments do not allow parking brake to fully engage, tighten the lever attachment nut on the transmission.

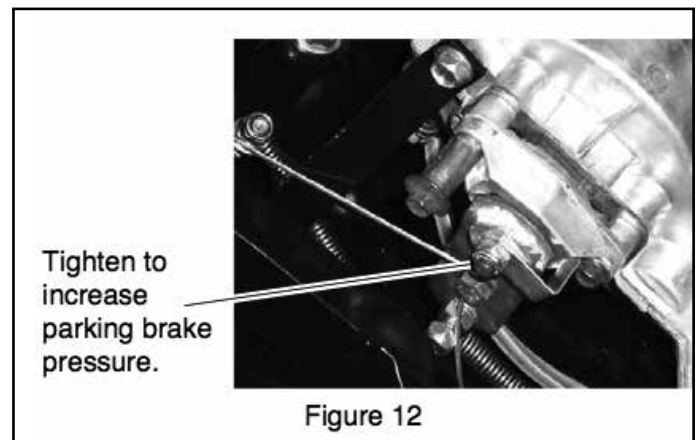

## SERVICE POSITION

(Figure 13)



To access the drive belt and cable attachment points place the unit in the service position by tipping it on its front wheels and front skip edge.

Be sure to move the fuel shut-off valve to the closed position before placing in service position (see *Fuel Shut-Off Valve* on page 7).

## DRIVE BELT REPLACEMENT

(Figure 14)

### Removal

1. Remove two M8 hex bolts retaining bottom panel at front of unit.
2. Place unit in service position (see SERVICE POSITION above).
3. Remove remaining four M8 hex bolts retaining the bottom panel and remove the panel.
4. Loosen the hex nut retaining the belt guide tube (item 1) enough to allow belt to be removed from transmission pulley (item 2).
5. Remove the belt guide bolt (item 7) from the idler arm (item 4).
6. Remove the belt from the unit.

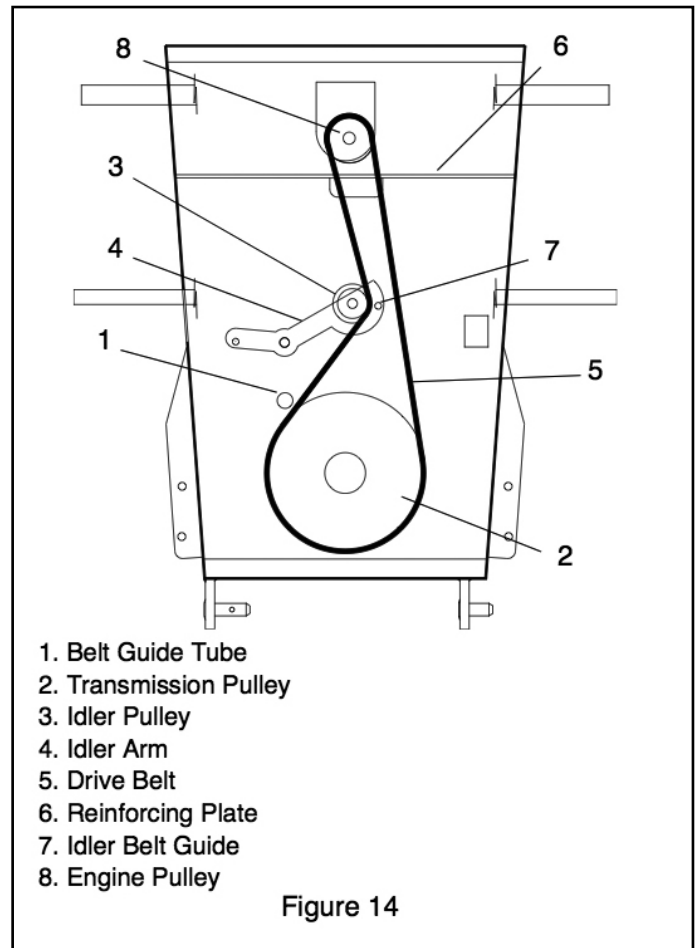

### Installation

1. Install replacement belt on transmission pulley (item 2).
2. Tighten belt guide tube (item 1).
3. Route belt to right side of idler pulley (item 3). Outer flat portion of belt will contact pulley.
4. Install idler belt guide bolt (item 7).
5. Route belt through opening in reinforcing plate (item 6) and onto engine pulley (item 8).
6. Adjust clutch as needed. See LEVER ADJUSTMENTS on page 9.
7. Install bottom panel.

# PARTS LIST

## COWLING, CONTROLS & SKIP

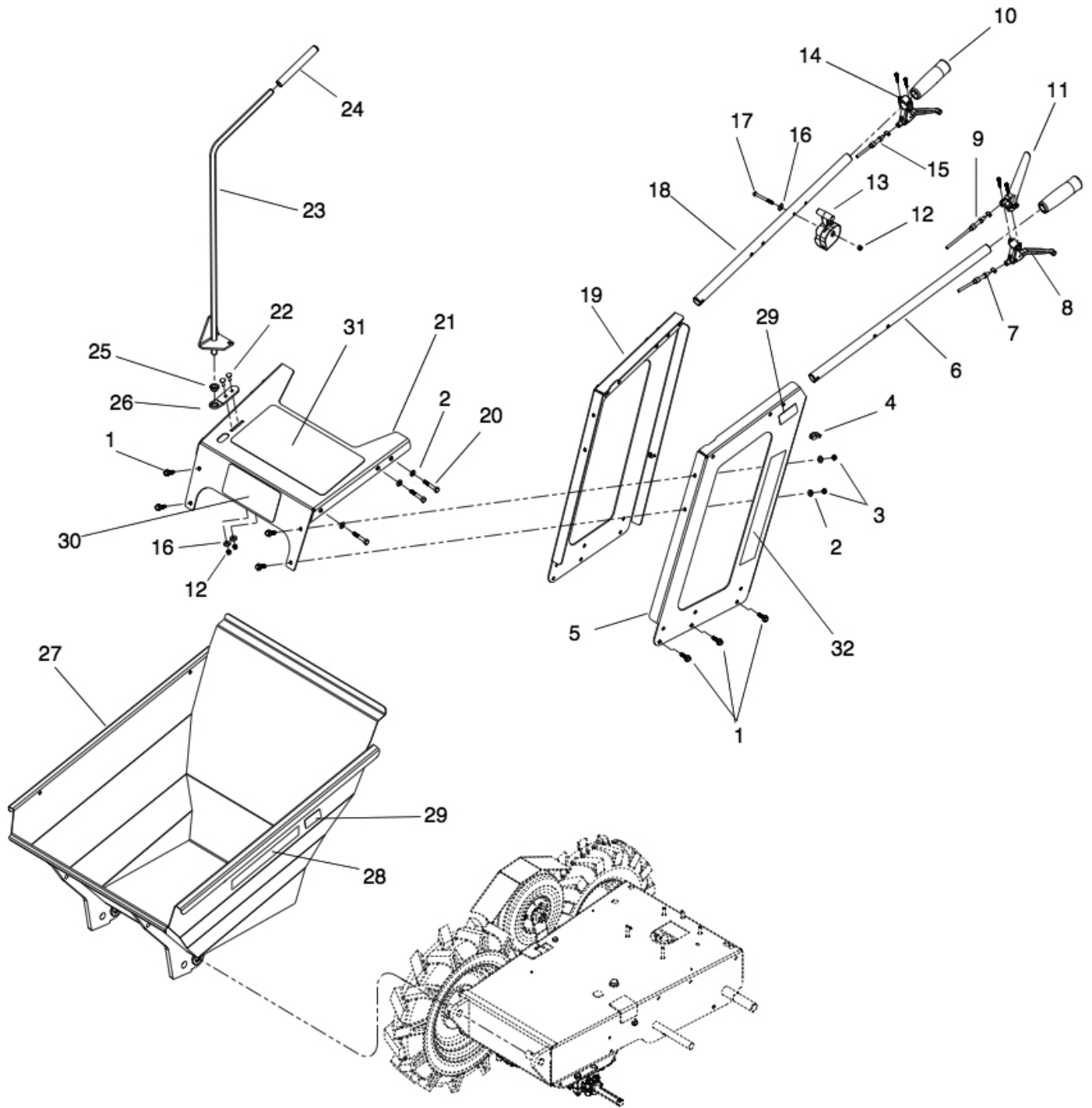

## COWLING, CONTROLS & SKIP (CONT'D)

Item	Part No.	Qty.	Description
1		18	Hex head setscrew M8 x 20
2		64	Washer, M8 form A.
3		40	Nut M8 Nyloc type P
4		2	Cable Tie 3.6mm x 140
5	MT 04032	1	Cowling Side Left Hand (Muck-Truck Mk V)
	MT 03956	1	Cowling Side Left Hand (MAX Mk III)
6	MT 03965	1	Tube, Handle – Left Hand (MAX Mk III)
	MT 04058	1	Tube, Handle – Left Hand (Muck-Truck Mk V)
7	MT 03943	1	Cable, Clutch Control
8	DP0502015	1	Lever, Clutch
9	MT 03943	1	Cable, Brake
10	DP03	2	Grip, Handle 22 mm x 135 mm
11	DP0502016	1	Lever, Brake Control - Red
12		3	Nut M6 Nyloc type P
13	MT 03991	1	Control, Throttle
14	DP0502014	1	Lever, Skip Catch, With Clamp and Screws
15	MT 03943	1	Cable, Skip Release
16		2	Washer, M6 form A
17		1	Bolt Hex, M6 x 65 long
18	MT 03966	1	Tube, Handle – Right Hand (MAX Mk III)
	MT 04059	1	Tube, Handle – Right Hand (Muck-Truck Mk V)
19	MT 04031	1	Cowling Side Right Hand (Muck-Truck Mk V)
	MT 03958	1	Cowling Side Right Hand (MAX Mk III)
20		4	Bolt, Hex M8 x 50 long
21	MT 04034	1	Cowling Cover (Muck-Truck Mk V)
	MT 03959	1	Cowling Cover (MAX Mk III)
22		2	Coach Bolt M6 x 20 long
23	MT 03961	1	Gear Change Lever (MAX Mk III)
	MT 04054	1	Gear Change Lever (Muck-Truck Mk V)
24	DT107	1	Grip, Gear Lever
25		1	Bearing, Flange 008 1603000 02
26	MT 03963	1	Gear Lever Guide Plate
27	MT 03034	1	Skip (Muck-Truck Mk V)
	MT 03975	1	Skip (MAX Mk III)
28		2	Decal, Skip – Load Capacity (Muck-Truck Mk V)
	MT 04015	2	Decal, Skip – MAX
29	MT 04016	4	Decal, Maximum Skip Load Capacity (MAX Mk III)
		2	Decal, Maximum Skip Load Capacity (Muck-Truck Mk V)
30	MT 04017	1	Decal, Maintenance
31	MT 03988	1	Decal, Operation
32	MT 04018	2	Decal, Muck-Truck

# TRANSMISSION AND BELT DRIVE

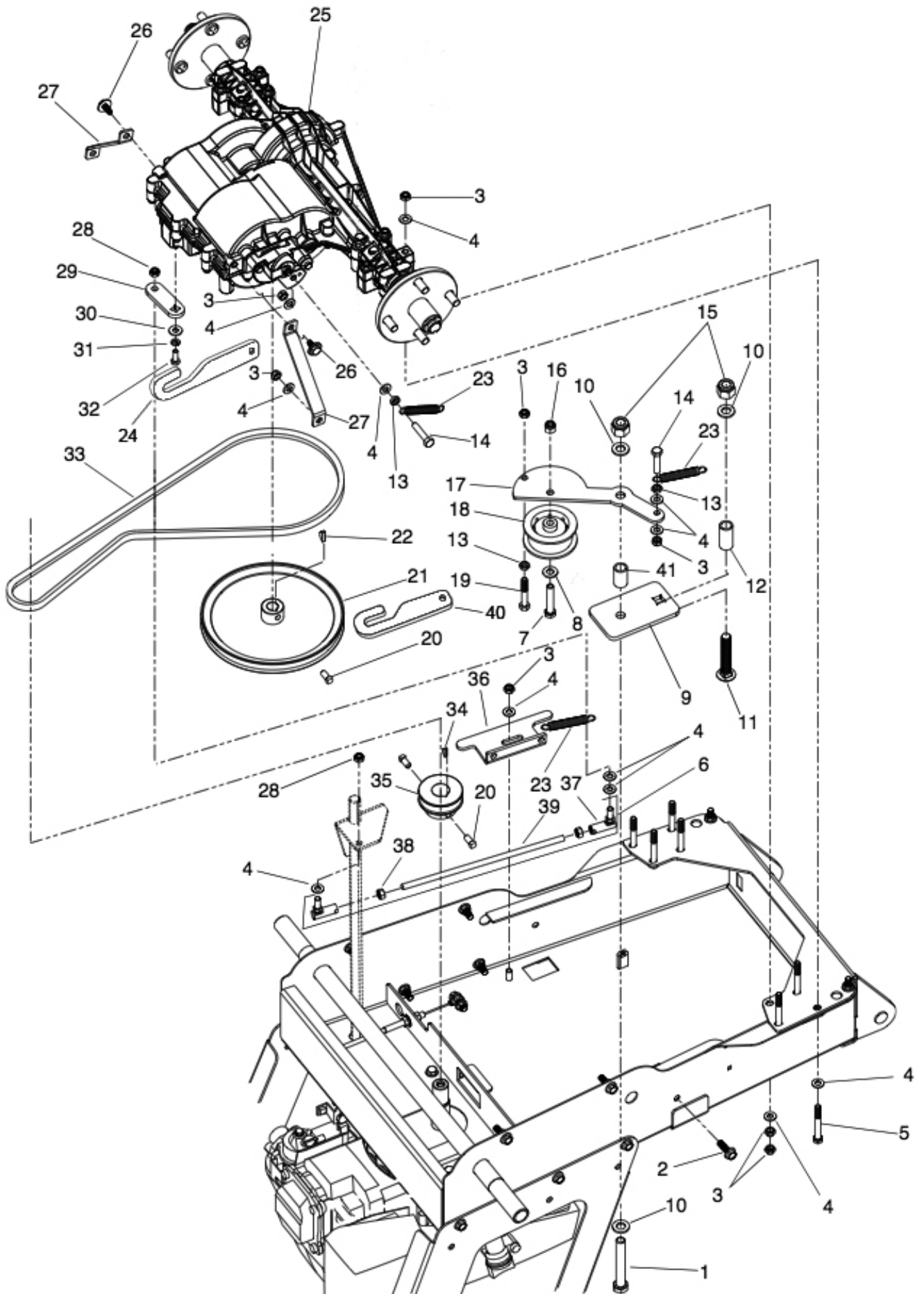

## TRANSMISSION AND BELT DRIVE (CONT'D)

Item	Part No.	Qty.	Description
1		1	Bolt, Hex head M12 x 75 long
2		18	Hex head setscrew M8 x 20 long
3		40	Nut M8 Nyloc type P
4		64	Washer, M8 form A
5		8	Bolt, M8 x 65 long
6	MT 03962	1	Gear Change Linkage (Includes items 37, 38 and 39)
7		1	Bolt. M10 x 45 long
8		2	Washer, M10 form A
9	DP 05043	1	Plate, Clutch Reinforcing
10		6	Washer, M12 form A
11		1	Coach Bolt M12 x 60 long
12	MT 03021	1	Tube, Belt Guide
13		3	Nut, M8 Full
14		5	Hex head setscrew, M8 x 35 long
15		4	Nut M12 Nyloc type P
16		1	Nut M10 Nyloc type P
17	MT 03951	1	Clutch Lever
18	MT 03953	1	Clutch Pulley
19		1	Bolt M8 x 60 long
20		3	Hex head setscrew, 5/16" UNC x 3/4" long *
21	MT 03942	1	Pulley, Transmission
22		1	Key, Woodruff 3/4" x 3/16"
23	DP18	3	Spring
24	MT 03945	1	Brake Arm Link
25	DP21	1	Transmission, Peerless
26		2	Setscrew, Hex head/flanged Self-Tapping M8 x 20 long
27	MT03020	2	Torque Stay
28		2	Nut M8 Nyloc type P
29	MT 03973	1	Plate, Shifter
30		1	Washer, M6 form C
31		1	Washer M6 Spring Lock
32		1	Hex head setscrew 1/4" UNF x 3/4" long
33	DP0502018	1	Belt, 51"
34		1	Key, Woodruff 3/32" x 5/8"
35	MT 03001	1	Pulley. Engine
36	MT 03977	1	Skip Release Catch
37		2	Ball Joint M8. Part of item 6
38		2	Nut, M8 full Part of item 6
39		1	Rod, Gear Linkage Part of item 6
40	MT 03944	1	Clutch Arm Link
41	MT 03942	1	Spacer, Clutch Pivot

• Torque to 15 – 20 lbf-ft.

# MAINFRAME & DRIVETRAIN

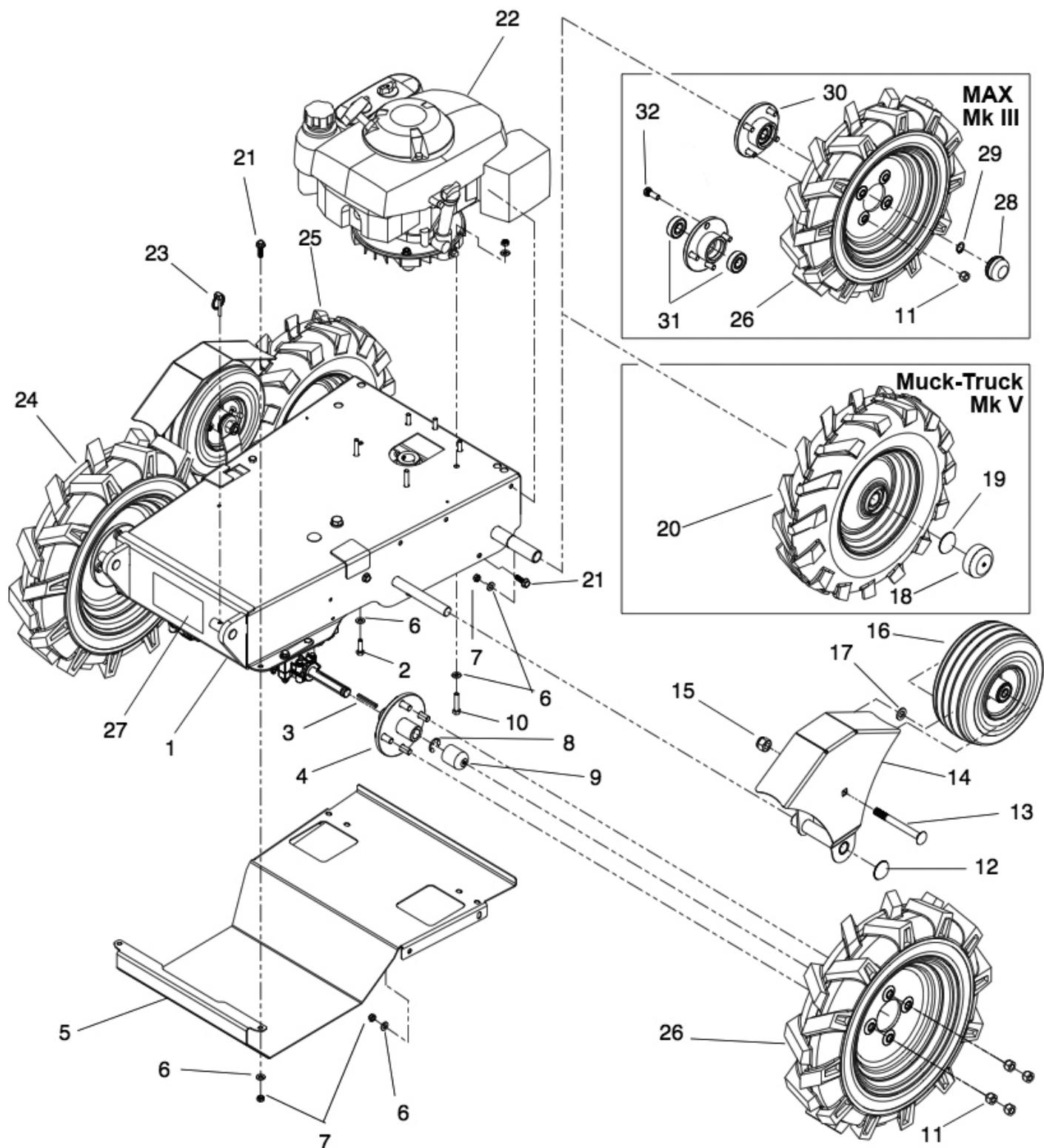

## MAINFRAME & DRIVETRAIN (CONT'D)

Item	Part No.	Qty.	Description
1	MT 04028	1	Mainframe (Muck-Truck Mk V)
	MT 03984	1	Mainframe (MAX Mk III)
2		4	Hex Head setscrew 5/16" UNF x 1" long
3		2	Key, Square 3/16" x 55mm long
4	DP 05041	2	Front Hub
5	MT 03948	1	Bottom Plate
6		64	Washer, M8 form A
7		40	Nut M8 Nyloc type P
8		2	E-Ring .750" x .050" N1500 Code 0075
9	DP80	2	Cap, Vinyl 1.25 x 1.625
10		5	Bolt, M8 x 40 long
11		16	Wheel nut M10 x 1.25 Pitch
12	DP83	2	Starcap 19mm
13		2	Coach Bolt M12 x 130 long
14	MT 03019	2	Power Drive Bracket
15		4	Nut M12 Nyloc type P
16	DP45	2	Wheel Assembly, Power Drive (4")
17		6	Washer, M12 form A
18		2	Chrome plated wheel cap
19		2	Circlip EXT0250
20	DP30 LH	1	Wheel Assembly, Left Hand Rear (Muck-Truck Mk V) (8")
21		18	Hex head setscrew M8 x 20 long
22		1	Engine, Honda GXV160
23	DP31	1	Pin, Lynch
24	DP24 RH	1	Wheel Assembly, Right Hand (Muck-Truck Mk V) (10")
	DP24 RH	2	Wheel Assembly, Right Hand (MAX Mk III) (10")
25	DP30 RH	1	Wheel Assembly, Right Hand Rear (Muck-Truck Mk V) (8")
26	DP24 LH	1	Wheel Assembly, Left Hand (Muck-Truck Mk V) (10")
	DP24 LH	2	Wheel Assembly, Left Hand (MAX Mk III) (10")
27	MT 04018	2	Decal, Muck Truck Logo
28		2	Chrome plated wheel cap
29		2	Circlip EXT0250
30	MT 03980	2	Hub Assembly, Rear Wheel (MAX Mk III)
31		2	Bearing, Ball 25 mm x 52 mm 6205 2RS
32		4	Wheel stud M10 x 1.25 pitch x 35 long



# WARRANTY

Serial Number:

Warranty is 12 calendar months from date of sale for Consumers and 90 days for units used in the Commercial Sector. Under the following conditions:

- Routine maintenance completed in accordance with Owners Manual.
- Returned defective parts are approved by Muck Truck UK Ltd.
- Machine is not abused or operated with known faults or lack of maintenance.
- Repairs are in accordance with Muck Truck UK Ltd.

## **AT AN AGREED JOB RATE**

Only defective parts are covered, and not wearable components that require replacement because of normal wear; for example puncture, chipped paint, dented skip etc. Muck Truck UK Ltd will not be held liable for any consequential losses.

## **PERSONAL CUSTOMER GUARANTEE STATEMENT**

If there is any component, or components, manufactured by Muck Truck UK Ltd. that are found to be defective within 12 months from the date of purchase (or 90 days in the case of a machine used for hire/commercial purposes), Muck Truck UK Ltd. will replace the faulty component(s) free of charge, provided they are notified immediately upon date of failure.

## **THE FOLLOWING ARE NOT COVERED BY THIS GUARANTEE**

1. Engines – Engines are guaranteed by their respective manufacturers.
2. A machine which has been subject to operation in excess of recommended capacities, misuse, negligence or accident, or has been altered or modified in a manner which has not been authorized by Muck Truck UK Ltd.
3. Wear parts – belts, cables etc.
4. Transportation Charge – to and from the warranty repair site.

**Muck Truck UK Ltd operates a policy of continual development and reserves the right to alter product specifications without giving prior notice**

Muck-truck UK Limited  
 Unit 34 F Compass Business Park, Pipers Close,  
 Pennygillam Industrial Estate,  
 Launceston, Cornwall, PL15 7EB  
 Tel: 01566 777140, Fax: 01566 777706, Email: info@mucktruck.com  
 Company Registration Number: 05316921 United Kingdom



## EC DECLARATION OF CONFORMITY

We, Muck Truck UK Ltd, Unit 34F Compass Business Park, Pipers Close, Pennygillam Industrial Estate, Launceston, PL15 7EB, England, hereby certify that the product described within this certificate is bought from an authorised Muck Truck dealer within the EU and conforms with the following EU directives: - Machinery Directive 2006/42/EC; Electromagnetic Compatibility Directive 2004/108/EC; Low Voltage Directive 2006/95/EC; Safety of Machinery EN ISO 12100-1:2003 + A1:2009; Mechanical Vibration ISO 5349 and associated harmonised standards, where applicable. Noise emissions conform to directive 2005/88/EC amended by 219/2009 for machines under article 12. The notified body is AV Technology Limited, Avtech House, Arkle Avenue, Stanley Green Trading Estate, Handforth, Wilmslow, SK9 3RW, England.

PRODUCT TYPE. Pedestrian Dumper.  
 MODEL. Muck Truck MK V and MAX Dumper MK III  
 SERIAL No.....  
 DATE OF MANUFACTURE.....  
 SOUND POWER LEVEL MEASURED. 94 dB Lwa  
 (GUARANTEED).  
 H.A.V.s  
 Left Hand idle – 2.79 m/s<sup>2</sup> racing – 4.95 m/s<sup>2</sup>  
 Right Hand idle – 3.10 m/s<sup>2</sup> racing – 5.86 m/s<sup>2</sup>

Signed by: 

Terry Rowlands.

Company Director

Managing Director - On  
 behalf of Muck Truck UK Ltd  
 (Authorised author of Technical File)

Terry Rowlands