



Machines

**Vibratory Rammers 62 – 83 Kg**  
ACR 60/68/70 D



Full power with operator's comfort in mind



# Three machines for universal application

## Universal machines

The Ammann range of rammers offers the highest performance, operator's comfort, economic viability, ergonomic design and useful optional equipment and therefore the optimal compaction machine for every construction application. The rammers can be operated under the toughest conditions in trench compaction work, back filling or in patch work on roads – even in the most confined areas.

## Three strong characters

The Ammann rammers ACR 60 and ACR 68 have been developed in accordance with the newest ergonomic and environmental requirements. They are both powered by a Honda GX 100 4-stroke petrol engine with automatic oil alert system (including a well-visible LED-warning lamp) and with a carburetor with integrated pump which assures a better fuel injection leading to an always optimal engine start up. The engine assures low emissions values meeting the US-EPA Tier III exhaust norms (important aspect for applications in confined areas with low air circulation). Furthermore it is resistant against dirty fuel and protected from damage by a solid metal casing.

The high compaction performance combined with an extraordinary fast forward motion, the operating weights with exactly 62 kilos resp. 68 kilos and the extreme low center of gravity, due to the low mounted engine and the downward distribution of the mass make both machines very robust and reliable products.

A height-adjustable, vibration reducing handle and a fuel reservoir with extended volume of 3 litres lead to a fatigue free operation for longer periods. Various sizes of shoe widths from 165 mm up to 400 mm assure a wide range of applications.

These new rammers contain many new and useful options:

- The machine height has been reduced by approx. 10 cm due to a special adapter plate (for the operation in back fills, especially when using extremely narrow shoes)
- Cyclone pre cleaner for the air filter (gives up to five times longer service intervals)
- Air filter service indicator
- Operation hour meter with engine speed indicator and reminder for oil change



The range of Ammann rammers is completed by the robust and strong model ACR 70 D powered by a Yanmar diesel engine and an operating weight of 83 kilos. As usual with your heavy duty construction machinery this rammer consumes diesel fuel so that just one type of fuel has to be made available on the job site.



## Highest flexibility in operation

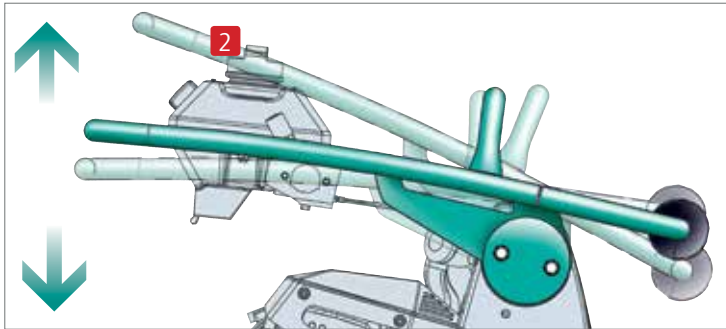

Optimal ergonomics thanks to height-adjustable guiding handle

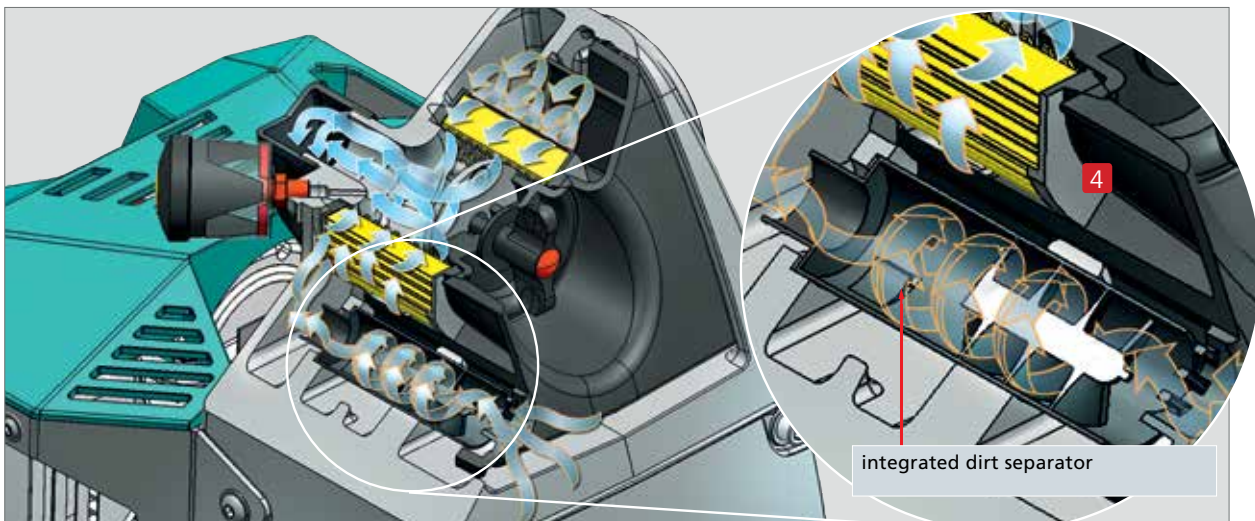

Voluminous but finely woven air filter with self-cleaning effect optionally equipped with a cyclone pre cleaner and a service indicator (gives up to five times longer service intervals)





- 1. High manoeuvrability in confined areas thanks to short guiding handle
- 2. Operator's comfort: sure-grip and vibration isolated guiding handle
- 3. Modern carburetor with integrated accelerator pump for trouble-free quick engine start
- 4. Solid engine protection casing
- 5. Standard engine equipment: automatic oil alert system with LED warning lamp
- 6. Additional handle for easy transport and loading
- 7. Tamper shoe made of high quality synthetic material with integrated steel plate – option: Wear and tear steel plate protection on both sides

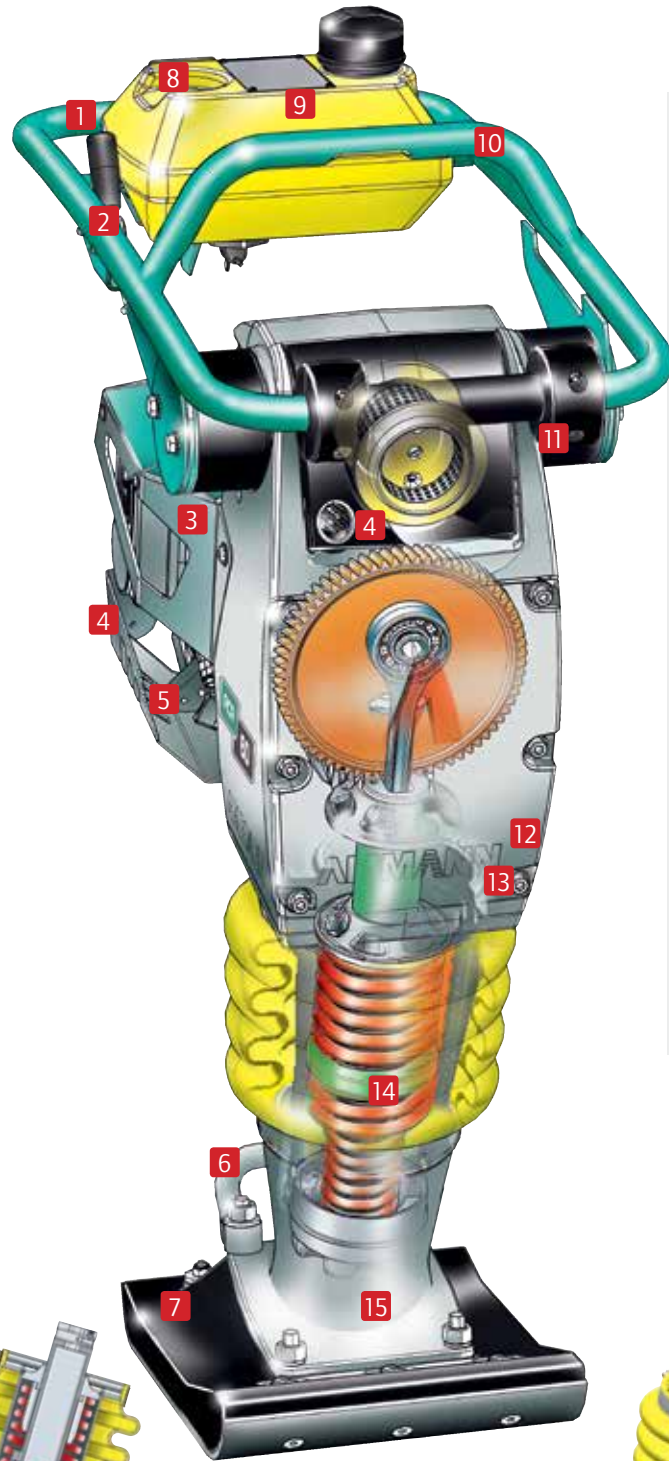

- 8. Fuel reservoir with extended volume and integrated filter
- 9. Hourmeter with engine speed indicator
- 10. Convenient transport device with centering
- 11. Additional rolls for easy loading and unloading
- 12. Improved forward motion thanks to lower center of gravity and fine tuned machine design
- 13. Robust gear box housing
- 14. Innovative spring assembly for a compact design of the spring leg

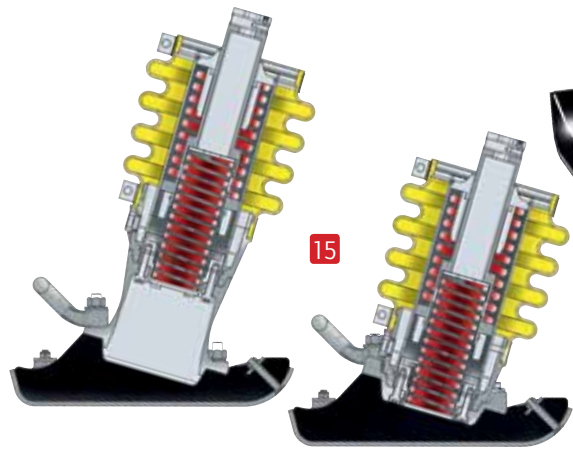

Option: reduction of machine height by approx. 10 cm by a special adapter plate



Option: reduction of machine height

# Technical Data

**Best in class thanks to an extraordinary fast forward motion** due to the extreme low center of gravity

**Patented height reduction of approximately 10 cm using an adapter plate (option)**



340 mm asymmetric: compaction work in trenches protected by shuttering systems without inclining the rammer during operation



Quick to solve only 4 screws

Patented height reduction of approximately 10 cm

Standard height

Extension

165 mm

200 mm

230 mm

280 mm (Standard)

330 mm

400 mm

340 mm asymmetric

280 mm option: Wear and tear steel plate protection on both sides



Dimensions		A	B	C	D	E
ACR 60	mm	340	280	710	1020 - 1120	355
ACR 68	mm	340	280	710	1020 - 1120	355
ADS 70	mm	340	280	780	950	365

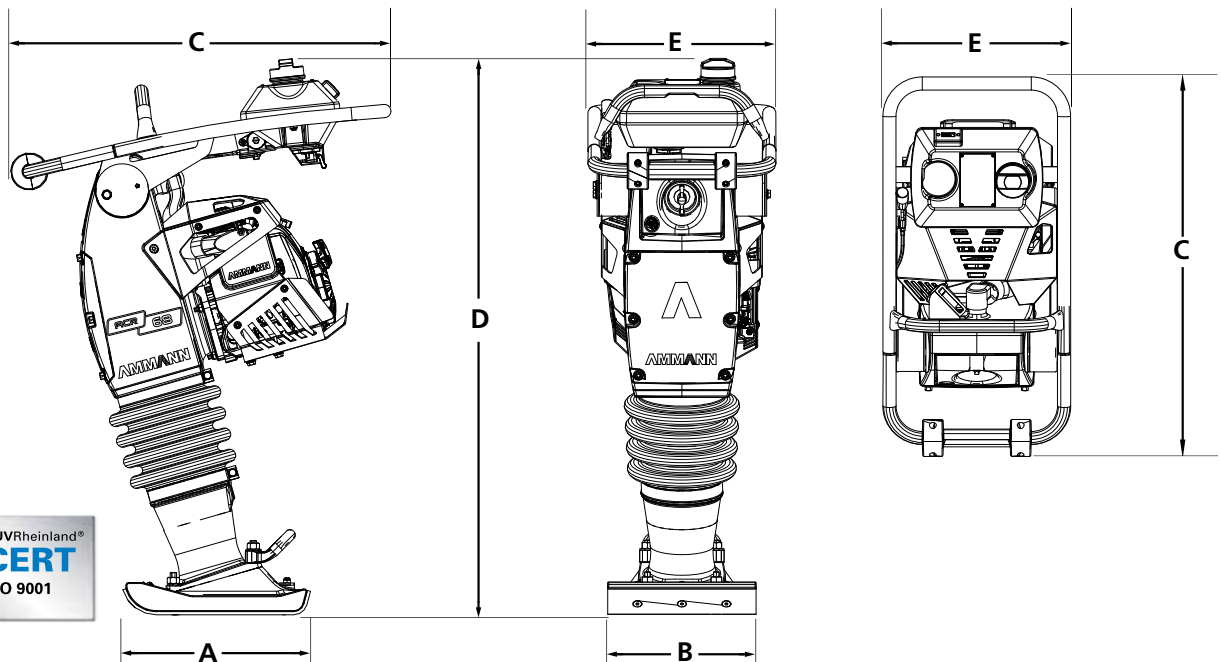

		ACR 60	ACR 68	ACR 70 D
Working width	mm (in)	280 (11)	280 (11)	280 (11)
Operating weight	kg (lb)	62 (137)	68 (150)	83 (183)
Engine/Type		Honda GX 100	Honda GX 100	Yanmar L 48 AE
Engine output	HP (kW)	3 (2,2)	3 (2,2)	4,4 (3,2)
at rpm	1/min. (rpm)	4300	4300	3250
Percussion rate	blows/min. (bpm)	680	680	730
Stroke	mm (in)	65 (2,6)	65 (2,6)	60 (2,4)
Centrifugal force	kN (lbf)	11,5 (2,6)	13 (2,9)	14 (3,1)
Surface capacity	m <sup>2</sup> /h (ft <sup>2</sup> /hr)	225 (2422)	225 (2422)	210 (2260)
Fuel tank capacity	l (gal)	3,5 (0,8)	3,5 (0,8)	3 (0,7)
Travel speed	m/min (mph)	13,5 (0,5)	13,5 (0,5)	13 (0,5)
max. compaction performance*	cm (in)	45 (18)	50 (20)	60 (23,6)
optional foot sizes width	mm (in)	165-200-230-330-400 (6,5-7,87-9,1-13-16)	165-200-230-330-400 (6,5-7,87-9,1-13-16)	230-260-330-400 (9,1-10-13-16)

\*depending on ground conditions

**Australia:** Ammann Australia Pty. Ltd. | Narangba 4504

**Austria:** Ammann Austria GmbH | 4113 St. Martin im Mühlkreis

**Brazil:** Ammann do Brasil | CEP: 94180-452 Gravataí/RS

**Bulgaria:** Ammann Bulgaria | 1700 Sofia

**China:** Ammann Construction Machinery Shanghai Co. Ltd. | Shanghai 201700

**Czech Republic:** Ammann Czech Republic a.s. | 54901 Nové Město nad Metují

Ammann Asphalt GmbH | 60200 Brno

**France:** Ammann France SAS | 94046 Créteil/Cedex

**Germany:** Ammann Asphalt GmbH | 31061 Alfeld (Leine)

Ammann Verdichtung GmbH | 53773 Hennef

Ammann Elba Beton GmbH | 76275 Ettlingen

**India:** Ammann Apollo India Private Ltd. | Ahmedabad 380 009

**Indonesia:** Ammann South East Asia | Jakarta 11530

**Italy:** Ammann Italy S.p.A. | 37012 Bussolengo

**Kazakhstan:** Ammann Kazakhstan LLP | Almaty 050051

**Netherlands:** Ammann Benelux B.V. | 7730 SK Ommen

**Poland:** Ammann Polska sp.z.o.o. | 02-230 Warszawa

**Romania:** Ammann Group Romania S.R.L. | 077125 Magurele

**Russia:** Ammann Russia o.o.o. | 127 473 Moscow

**Singapore:** Ammann Singapore Pte. Ltd. | 307591 Singapore

**Spain:** Ammann Iberia S L | Madrid

**South Africa:** Ammann Construction Machinery South Africa | Benoni 1500

**Sweden:** Ammann Scandinavia | 211 20 Malmö

**Switzerland:** Ammann Switzerland Ltd. | 4901 Langenthal

Avesco AG | 4901 Langenthal

**Turkey:** Ammann Teknomak A.S. | Ankara 06370

**Ukraine:** OOO Ammann Ukraine | 03150 Kiev

**United Arab Emirates:** Ammann NME FZE | Dubai

**United Kingdom:** Ammann UK Ltd. | Warwickshire CV37 0TY

**USA:** Ammann America Inc. | Ponte Vedra | Florida 32082

Detailed information can be found at: [www.ammann-group.com](http://www.ammann-group.com)